

THIS COPY IS PROVIDED ON A RESTRICTED BASIS AND IS NOT TO BE USED IN ANY WAY DETRIMENTAL TO THE INTERESTS OF PANDUIT CORP.

PANDUIT PART NUMBER	STUD SIZE	DIMENSIONS in.				
		A ±.030	W ±.010	C ±.020	M ±.030	H ±.010
PNF18-6LF-3K	#6	.85 (21.59)	.27 (6.86)	.19 (4.82)	.63 (16.00)	.15 (3.81)
PNF18-6LFW-3K	#6	.85 (21.59)	.29 (7.37)	.19 (4.82)	.63 (16.00)	.15 (3.81)
PNF18-8LF-3K	#8	.89 (22.61)	.29 (7.37)	.23 (5.84)	.68 (17.27)	.16 (4.06)
PNF18-10LF-3K	#10	.89 (22.61)	.33 (8.38)	.23 (5.84)	.68 (17.27)	.19 (4.83)

NOTES :

- UL LISTED AND CSA CERTIFIED FOR :
  - 600 V MAX. VOLTAGE RATING (1000V. MAX. IN SIGNS, FIXTURES & LUMINARIES)
  - 221°F (105°C) MAX. TEMP. RATING OF INSULATION MATERIAL
  - #22-18 AWG (0.5-1.5 mm<sup>2</sup>) SOLID OR STRANDED, COPPER WIRE
- PACKAGE QTY. : 3K = 3000 PCS.  
CONTINUOUS MOLDED CARRIER STRIP
- MATERIAL :
  - STAMPING - .03" THK COPPER, TIN PLATED
  - HOUSING - RED NYLON
  - SLEEVE - BRASS, TIN PLATED
- WIRE STRIP LENGTH:  $1/4^{+1/32}_{-0}$  (6.4<sup>+.80</sup><sub>-.00</sub>)
- DIMENSIONS IN BRACKETS ARE IN MILLIMETERS
- INSTALLATION TOOLS :
  - PRESSES - CP-851, CP-860, CP-861
  - APPLICATOR - CA-800
  - DIE INSERTS - CD-800-1



LISTED  
587H  
E52164



CERTIFIED  
LR31212

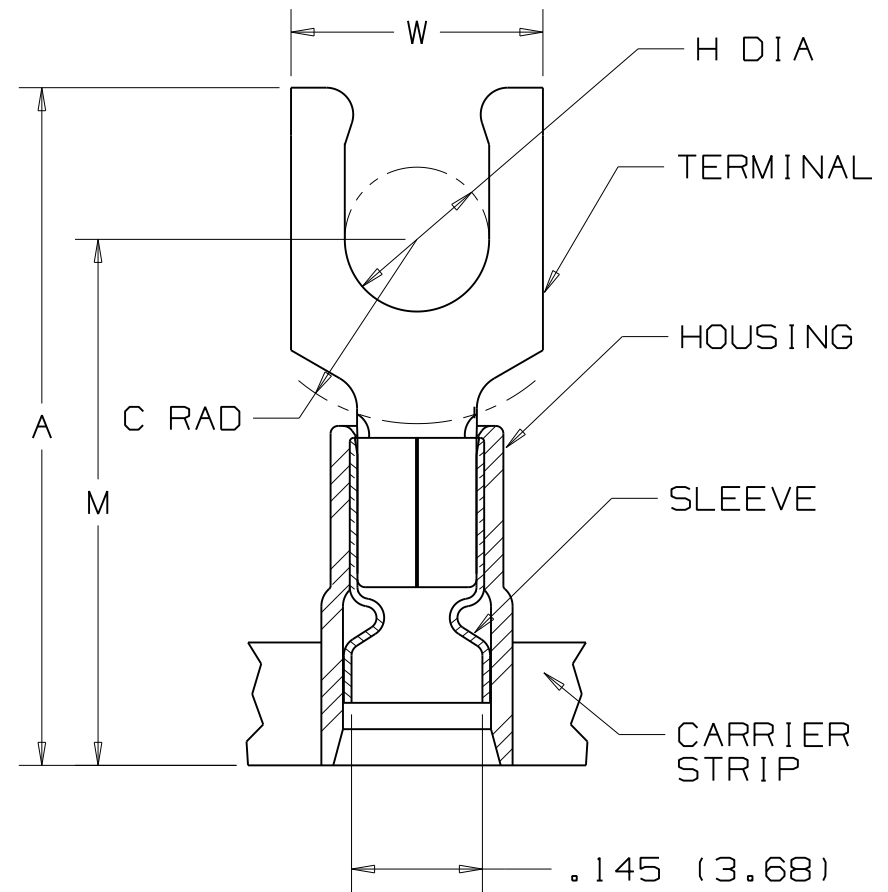

.145 (3.68)  
MAX WIRE  
INSUL DIA  
.090 (2.29)  
MIN WIRE  
INSUL. DIA.

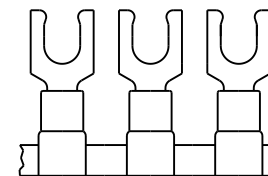

08	11/07	SRB1		Removed part # PNF18-10LFN-3K, Part obsoleted				
REV	DATE	BY	CHK	DESCRIPTION	ECN	CUST	PM	

**PANDUIT**

CORP. TINLEY PARK, ILLINOIS

TERMO 3PC. CONTINUOUSLY MOLDED NYLON (FUNNEL)  
INSULATED, 22-18 BARREL, LOCKING FORKS

DRAWN BY	CHK'D	SCALE	DRAWING NO.
GRM	FS	NONE	A41148